

TPC-30T TPC-32T

**3.5" QVGA TFT LCD XScale® PXA270
Touch Panel Computer**

**3.5" QVGA TFT LCD XScale® PXA270
Touch Panel Computer with CAN-bus**

NEW



Features

- Intel® PXA270 processor on board
- 3.5" color TFT LCD
- Super slim and compact design with plastic housing
- Fanless cooling system
- NEMA4/IP65 compliant front panel
- Built-in flash memory and Windows® CE OS
- 1 x SD card slot
- Automatic data flow control RS-485

Introduction

The TPC-30/32T has a super slim compact design and uses a low voltage processor and heat sink to achieve a unique fanless design. With its NEMA4/IP65 front panel it is resilient enough to resist the harsh conditions of any industrial environment. TPC-30/32T provides the Intel XScale PXA270 low voltage processor. With a 320 x 240 resolution and high graph display, it renders image on display clearly. Furthermore, the TPC-30/32T provides multiple standard communication ports allowing connectivity with a variety of peripherals. The TPC-30T also supports Windows CE OS let it become an Open HMI solution for system integration.

Specifications

General

- **Certifications** BSMI, CCC, CE, FCC, UL
- **Cooling System** Fanless design
- **Dimensions (W x H x D)** 120.79 x 85.5 x 26.5 mm (4.76" x 3.37" x 1.04")
- **Enclosure** ABS
- **Mounting** Panel
- **OS Support** Windows CE 5.0/6.0 (English Version)
- **Power Consumption** 8 W (typical)
- **Power Input** 8 ~ 28 V_{DC}
- **Watchdog Timer** Programmable as 250 ms, 500 ms, 1 second
- **Weight (Net)** 0.25 kg (0.55 lbs)

System Hardware

- **CPU** Intel PXA270 312 MHz
- **Memory** 64 MB on board SDRAM
- **LAN** 10/100Base-T x 1
- **Storage** 32 MB on board NOR flash
SD slot x 1 (SDIO)
- **I/O** TPC-30T: RS-232/485 x 1 (COM1) with auto data flow control
USB 1.1 x 1
TPC-32T: Isolated CAN 2.0B Interface/RS-232 x 1 (RS-232 for debug mode)
CAN Controller: SJA-1000
CAN Transceiver: 82C250
USB 1.1 x 1

LCD Display

- **Display Type** QVGA TFT LCD
- **Display Size** 3.5"
- **Max. Resolution** 320 x 240
- **Max. Colors** 64 K
- **Luminance cd/m²** 200
- **Viewing Angle (H/V)** 120/110
- **Backlight Life** 30,000 hrs
- **Contrast Ratio** 300 : 1

Touchscreen

- **Lifespan** 1 millions times with a silicone rubber of 8 mm diameter finger
- **Light** Transmission Above 80%
- **Resolution** Linearity
- **Type** 4-wire, analog resistive

Environment

- **Humidity** 10 ~ 95% RH @ 40° C, non-condensing
- **Ingress Protection** Front panel: NEMA4, IP65
- **Operating Temperature** 0 ~ 50° C (32 ~ 122° F)
- **Storage Temperature** -20 ~ 60° C (-4 ~ 140° F)
- **Vibration Protection** 1 Grms (5 ~ 500 Hz)
(Operating, random vibration)

Dimensions

Unit: mm

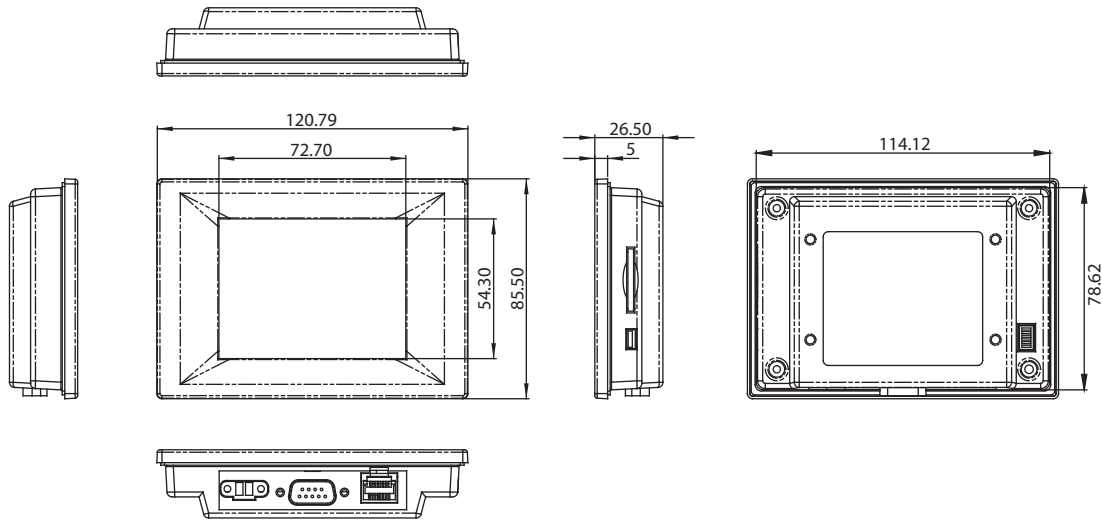

Panel Cut-out Dimensions: 115 x 79.5 mm

Ordering Information

- **TPC-30T-E2AE** 3.5" QVGA TPC, PXA270 312 MHz, 64 MB
- **TPC-32T-E2AE** 3.5" QVGA TPC, PXA270 312 MHz, CAN-bus
- **PWR-247-AE** 24 V 50 W AC-DC Power Adapter

Rear View

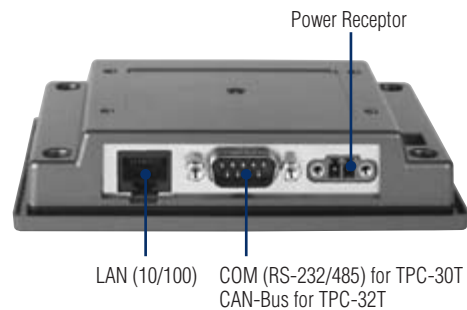

Side View

