

PWS-8101M

10.4" XGA TFT LCD Intel® Core™ 2 Duo Ultra Rugged Mobile Computer with Wi-Fi

NEW



CE FCC

Features

- Intel® Core™ 2 Duo U7500 processor
- 10.4" XGA TFT LCD transfective technology (optional)
- IP65 rating guarantees total protection against dirt, dust and water
- Certified by MIL-STD-810F and MIL-STD-461E
- Front panel key-pad buttons with numbers provides user friendly features
- High capacity rechargeable Li-ion battery with 4-hrs continuous operation
- Outdoor communication application with 802.11a/b/g, bluetooth
- Supports Windows XP Pro Embedded / XPe/ Vista Embedded
- Provides various mounting and enclosure accessories.

Introduction

The PWS-8101M is an ultra rugged mobile computer featuring a 10.4" XGA ATFT LCD, Intel Core 2 Duo U7500 processor Wi-Fi, and built-in bluetooth. PWS-8101M provides full-function communication for any outdoor application. Certified by military grade MIL-STD-810F and MIL-STD-461E standards, PWS-8101M is constructed with 6-side IP65 for dust and water resistance. Driven by a high capacity battery, PWS-8101M can provide hours of use while meeting rugged demands, such as 3 foot drop, and an extreme operating temperature range. With world leading Intel Core 2 Duo processor technology, PWS-8101M provides a strong device for reliable mobile communications in any environment.

Specifications

General

- **BIOS** Award® 8 MB
- **Certifications** CE, FCC, CB, MIL-STD-461E, MIL-STD-810F
- **Cooling System** Waterproof Fan
- **Dimensions (W x H x D)** 310 x 236 x 42 mm (12.2" x 9.29" x 1.65")
- **Enclosure**
Front: ABS
Back Housing: Al-Mg
Battery: Li-ion battery, 11.1 V, 5200 mAh
AC power Adapter: Universal AC 100 ~ 240 V,
50 ~ 60 Hz input; 19 V, 3.16 A output, stylus
- **Optional Accessories** Hand strap & shoulder bag, vehicle dock enclosure,
vehicle mount enclosure, VESA bracket, battery pack,
car adapter
- **OS Included** Windows XP Pro Embedded
- **Power Consumption** 34 W
- **Power Input** 18 ~ 20 V_{DC}
- **Weight (Net)** 2.9 Kg (6.54 lbs)

System Hardware

- **CPU** Intel Core 2 Duo U7500
- **Chipset** Intel GME965 + ICH8M
- **Memory** 1GB SO-DIMM DDRII 533 SDRAM (Up to 2GB)
- **LAN** 1 x 10/100/1000Base-T
- **Expansion** 1 x CF type II slot
1 x PCMCIA type II slot, supports CardBus 2.1
- **Storage** 1 x 2.5" 80GB SATA HDD
- **I/Os** 2 x RS-232
2 x USB 2.0
1 x VGA Port
1 x Mic-in, Line-out

- **Wireless** 802.11a/b/g
- **Bluetooth** Class 2, V2.0+EDR
- **GPRS** 3.5G/HSDPA (Option)
- **GPS** SiRF III (Option)

LCD Display

- **Display Type** XGA TFT LCD
- **Display Size** 10.4"
- **Max. Resolution** 1024 x 768
- **Max. Colors** 16.2M
- **Luminance (cd/m²)** 400
- **Viewing Angle (H/V°)** 176 / 176
- **Backlight Life** 50,000 hrs
- **Contrast Ratio** 1200:1

Touch Panel

- **Lifespan** 1 million touches at single point
- **Light transmission** Above 75%
- **Resolution** Linearity
- **Type** 4-wire, analog resistive

Environment

- **Humidity** 5%~95% non-condensing
- **Ingress Protection** 6-side IP65
- **Operating Temperature** -20 ~ 60° C (-4 ~ 140° F)
- **Storage Temperature** -40 ~ 70° C (-40 ~ 158° F)
- **Vibration Protection** 1.29 Grms (operating, random vibration)

Ordering Information

- **PWS-8101M-D2AE** 10.4" Ultra Rugged Mobile PC, Core 2 Duo, WLAN

Dimensions

Unit: mm

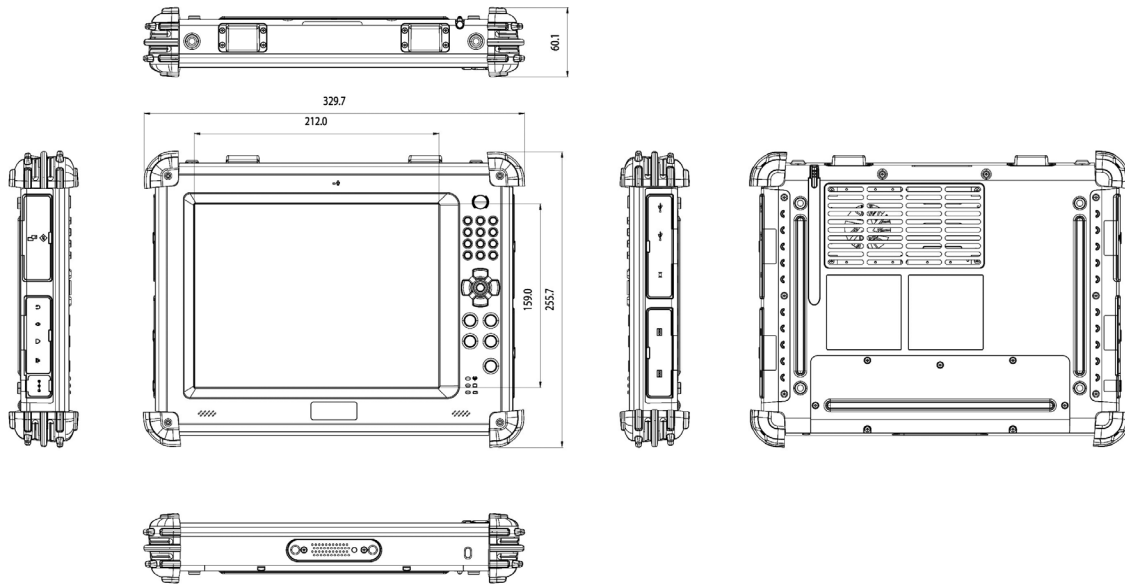

Accessories



Hand strap & Shoulder Bag



Vehicle Dock Enclosure



VESA Bracket



Battery Pack



Car Adapter (Supports 12~32VDC or 36-48VDC)

Top View



- Power Button
- Numeric Keys
- 4-way Navigation Buttons
- Customized Function Buttons
- Virtual Keyboard

Side Views

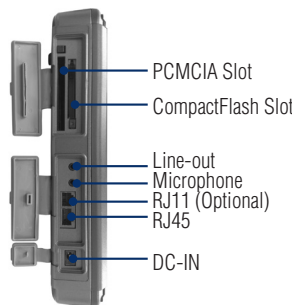

- PCMCIA Slot
- CompactFlash Slot
- Line-out
- Microphone
- RJ11 (Optional)
- RJ45
- DC-IN

- USB 2.0 x 2
- VGA
- RS-232